

PROFILES

COLORS

*** LOK-SEAM®**
Roofing System that Locks and Seams

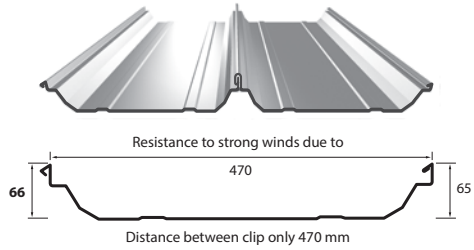

***NordicSeam128™**
Roofing System that Locks and Seams

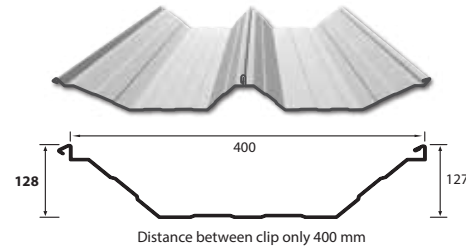

*** NordicLok®** - for Roof Panel

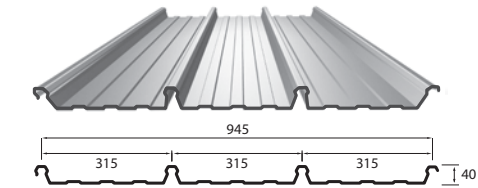

*** NordicRoof™** - for Roof Panel

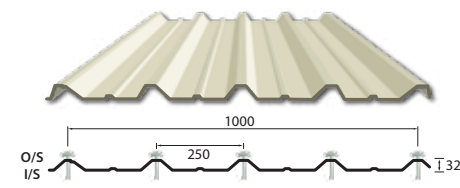

*** NordicWall™** - for Wall Panel

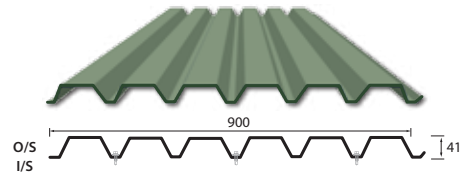

*** NordicLiner™** - Liner Panel for Roof & Wall

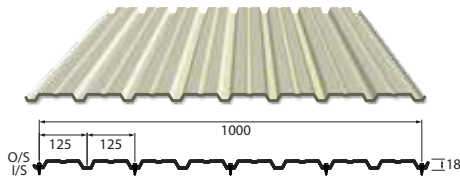

*** NordicDek®(Deck)** - thickness: 1mm

NordicDek® 76

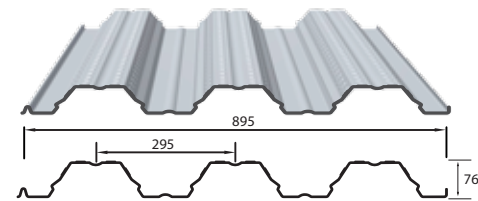

NordicDek® 55

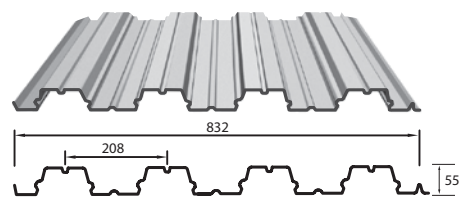

White Cream



BMT: 0.42 mm
APT: 0.50 mm

Green Tea

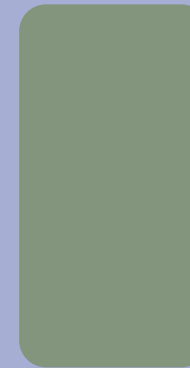

BMT: 0.42 mm
APT: 0.50 mm

Opal Green



BMT: 0.42 mm
APT: 0.50 mm

Alumin

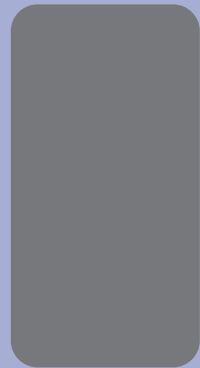

BMT: 0.42 mm
APT: 0.50 mm
Hyper 180™

Blue Tooth



BMT: 0.42 mm
APT: 0.50 mm

PEB Blue



BMT: 0.42 mm
APT: 0.50 mm
Hyper 180™

Alu-Zinc



TCT: 0.50 mm, 1.0 mm

Silver180™



TCT: 1.0, 1.5, 1.9, 2.4, 3.0 mm

ACCESSORIES

ACCESSORIES

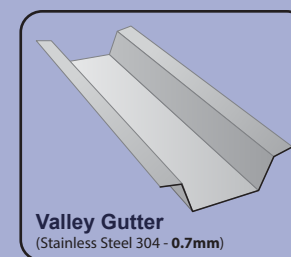
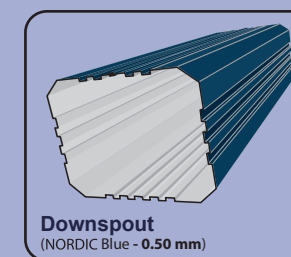
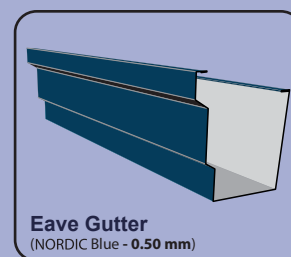
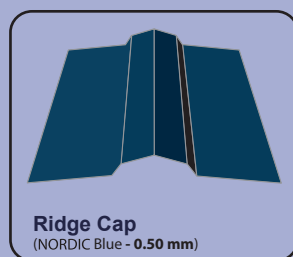
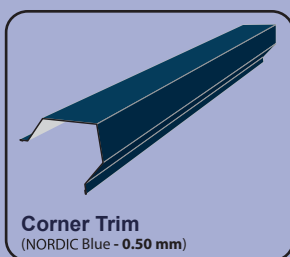
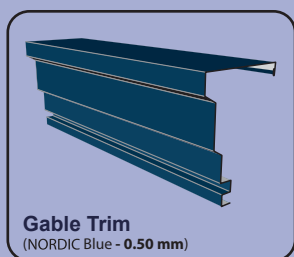

GREEN MATERIALS FOR BUILDINGS

AluNordic® Super Polyester Painted AZ150 AluZinc

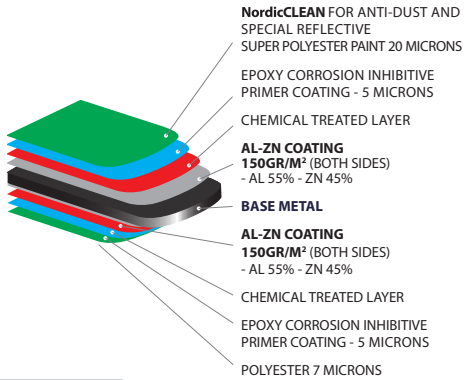

Roof & Wall

NordicLeed® Best Heat Reflectance Coils

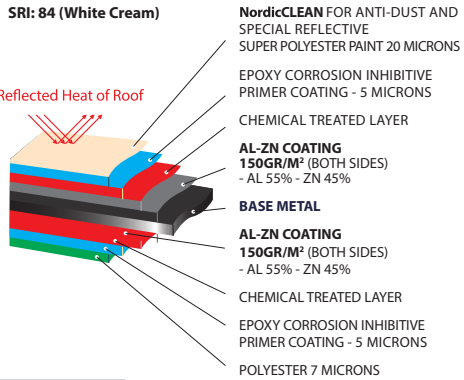

Roof & Wall

Hyper180™ No Color Change

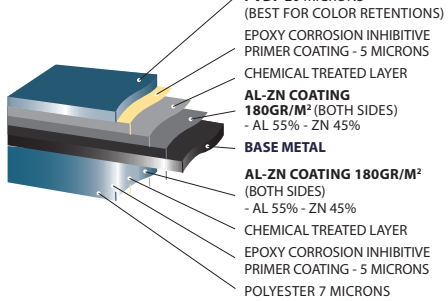

Roof & Wall

* PVDF: Polyvinylidene fluoride

Alu-Zinc™ Bare AZ150 AluZinc



Roof & Wall

Silver180™ Ultimate Corrosion Protection

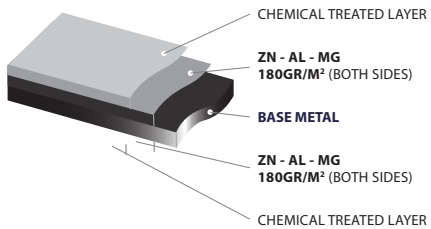

Roof, Purlins & Deck

GalvaNordic™ - Zero Spangle Galvanized Purlin Purlin & Girt: C & Z Shape Hot-dipped zinc coating high tensile steel (275gr/m² total Zinc Coating)

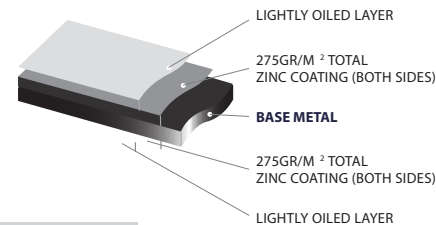

Purlin & Deck

Feb, 2019



By EFTCG
NORDIC
S T E E L

NORDIC STEEL

PURLIN, DECK & PANEL CHART

